

Ayre QX-8

Owner's Manual

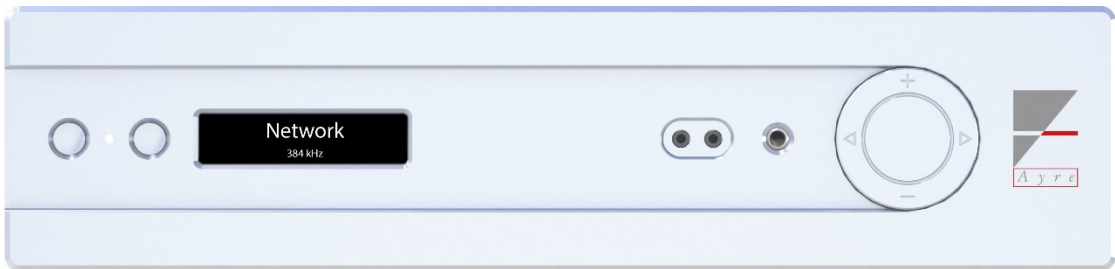

Digital Hub

Table of

Contents

Welcome to	Ayre	4
Connection and	Installation	6
Controls and	Operation	13
Setup and	Customization	18
Streaming and	Networking.	28
Numbers and	Specifications	34
In Case of	Trouble	35
Statement of	Warranty	38
A Place for	Notes	42

Welcome to

Ayre

To our North American customers, please be sure to mail in your warranty registration card.

Thank you for purchasing the QX-8 Digital Hub. We sincerely hope you get as much joy listening through it as we did designing and building it.

Our team has been designing world-class, award winning products since 1993. It is our goal to make the most musically accurate equipment we possibly can at any given price range. We enjoy designing, building, and talking about what we do. If you have any questions about your new Ayre product, please don't hesitate to give us a call.

Your QX-8 is the culmination of decades of audio innovation, distilling elements from Ayre's most celebrated works into one powerful piece of equipment. As always, the warmth and immediacy of a live performance are apparent from the first listening. Combining superb resolution and a natural, relaxed quality, your QX-8 will draw you into the music time and time again.

This level of performance has been implemented using the highest level of workmanship and materials. You can be assured the QX-8 will provide you a lifetime of musical enjoyment.

Quick Start

The information required to install, operate, and optimize your digital hub is contained in the following three chapters of this manual. The remaining chapters cover additional information that may be read at your leisure.

The button to the left of the display also allows you to cycle through the QX-8's inputs.

To begin enjoying your QX-8, connect it to your preamplifier or directly to a power amplifier if you plan to use the built-in digital volume control. You may also use a wired or wireless Ethernet connection to begin streaming music.



For the most current information on streaming music with your QX-8, visit the streaming section of our website: <https://streaming.ayre.com>

Next supply the QX-8 with power from a wall outlet. Toggle the rear power switch to the ON (I) position to provide power to the unit.

Press the left-hand button on the front of the QX-8 or use the power button on the included remote control to wake the unit from sleep. Use the left and right arrows of the control ring (on the faceplate) or left and right arrow keys (on the remote control) to select the input you wish to use. Change the volume pressing either the + or – symbols on the control ring or the up or down arrows on the remote control.

Installation

The Ayre QX-8 is easy to set up and use. The following guidelines will ensure the installation goes smoothly. At this point, you should consider how you would like to use the QX-8 in your system and how to incorporate your other equipment.

In this section, you will find descriptions of the various connections that are available on your QX-8, as well as recommendations for their intended use.

Location

A good location for the QX-8 is in an open-backed cabinet or on a shelf. The digital hub will only produce a small amount of heat during operation but having an adequate supply of air flow around your audio equipment is always a good idea.

The infrared beam will travel through glass.

The receiver for the remote control is between the two front panel buttons. A line of sight from the listening position will ensure maximum range.

Break-in Period

Once installed, a break-in period of around 100 to 500 hours will allow the amplifier to reach its full sonic potential.

Due to the manufacturing processes used for the wires, capacitors, and circuit board materials, a break-in period is necessary for the digital hub to reach its full sonic potential.



The main digital and analog circuitry will break-in regardless of which connection you use. Each type of digital input, however, may have a small amount of its own break-in period.

Digital Inputs

The USB and Ethernet inputs on the QX- 8 are options which can be included when the product is first ordered, or they can be added at a later time.

The Digital base option of the QX-8 includes six inputs, one AES balanced input (AES/EBU), two RCA (S/PDIF 1 and 2), and three TOSLINK (Optical 1, 2, and 3).

The USB option includes one USB type B port for asynchronous USB audio (USB Audio Input).

The Network option allows you to connect to your local area network (Ethernet Input). There are also two USB ports (USB Host) which allow you to connect wirelessly using the included USB Wi-Fi adapter and/or directly access files from a USB flash drive.

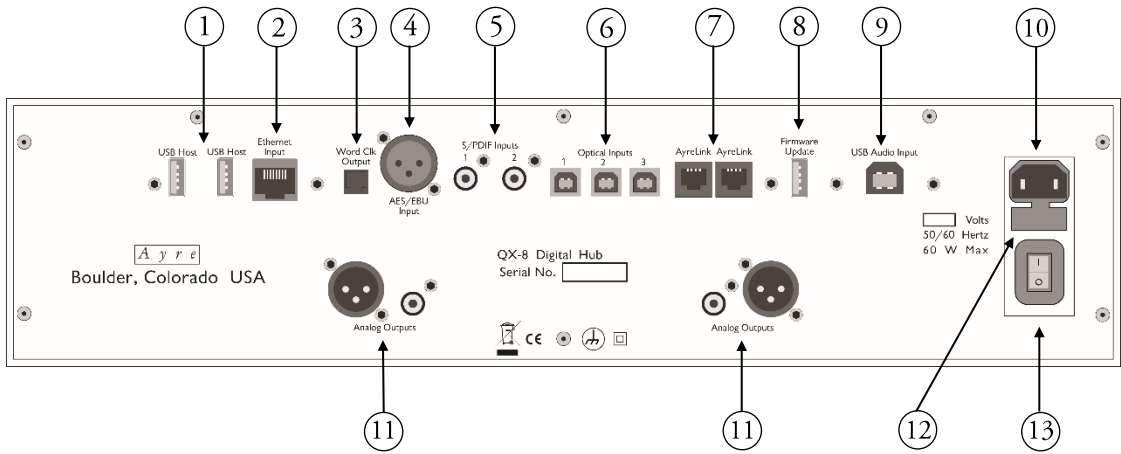

- | | |
|-------------------------|-------------------------|
| 1) USB Host Ports | 9) USB Audio Input |
| 2) Ethernet Input | 10) IEC Power inlet |
| 3) Word Clock Output | 11) Analog outputs |
| 4) AES/EBU Input | 12) AC Fuse holder |
| 5) S/PDIF Inputs | 13) On/Off Power Switch |
| 6) Optical Inputs | |
| 7) AyreLink Ports | |
| 8) Firmware Update Port | |

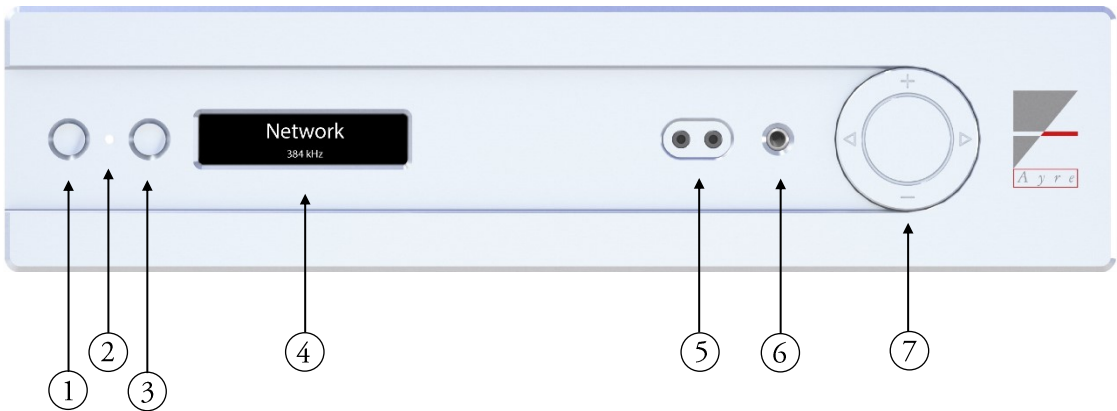

- 1) Left-hand Button
 - Sleep/Mute
- 2) IR Receiver / Status LED
- 3) Right-hand Button
 - Input Select
- 4) Display
- 5) 3.5mm Balanced Headphone Out
- 6) ¼" Single-ended Headphone Out
- 7) Control Ring

Analog Outputs

The QX-8 connects to your preamplifier, integrated amplifier, or power amplifier via the main outputs. The pair of XLR outputs provide a high quality connection to your system. A pair of RCA outputs are also provided for legacy equipment.



Using balanced cables with the XLR outputs will result in the best sound quality.

Headphone Outputs

The QX-8 automatically detects when headphones are plugged in. The main outputs are disabled while the headphone outputs are active.

1/4" Headphone Jack:



Single-ended

3.5mm Headphone Jacks:



Balanced

Headphones can be connected easily to the front of the QX-8. Between the display and control ring you will find three connectors; one for single-ended headphones and two for a set of balanced headphones. The single 1/4" on the right will allow you to listen in single-ended mode.

The two 3.5mm connectors on the left will allow you to listen to headphones in balanced mode. These outputs are not compatible with single-ended headphones.



Headphones with a 3.5mm stereo connector can be used with the QX-8 by using a 1/4" to 3.5mm adapter.



Only use headphones with stereo phone plugs (two insulating rings). Mono phone plugs (single ring) may damage the unit. Four conductor (three rings) plugs may not connect properly, distorting the sound.

AyreLink Ports

To use AyreLink with an integrated control system, an optional RS-232 adapter box is available. Contact your Ayre dealer for details.

The AyreLink communication system allows Ayre components to communicate with one another in your system. This seamless communication lets Ayre products work together to turn on and off components, switch inputs, report problems, and more. This makes using your Ayre system easier and more convenient than having to control each component individually.

There are two AyreLink ports on the rear panel of the QX-8. Each port has four contacts and contains both an input and an output. Both ports function identically and may be used interchangeably.



If not using the AyreLink cable that was provided with your unit, be sure to use two-line telephone cords to make AyreLink connections. These can be identified by the four gold contacts on each connector.

The linked components may be joined in any convenient order.

The linked components should be connected in daisy-chain fashion, connecting each component to another until all the linked components have been connected.



When connecting the linked components to form a chain, be careful not to connect the two ends of the chain. Closing the chain to form a loop will cause the AyreLink system not to function.

Word Clock Output

The word clock output lets you synchronize a digital source to the QX-8.

Some digital products have word clock inputs and provide higher performance when supplied with a high-quality external word clock. The word clock output in the Ayre QX-8 is derived from the ultra-low phase-noise master clock built into the Digital base option.

Firmware Update Port

The Firmware Update port allows you to update core Firmware with a USB flash drive. For more information, see page 25.

Operation

The following chapter details operation of the QX-8. On the front of the unit, you will find two buttons, a status LED, a display, an IR receiver for the remote, and a control ring. In addition to these controls, some network applications can provide further integration with the unit.

System-sleep Mode

While in sleep mode, the audio portion of the QX-8 is kept at optimal temperature to provide the best sound quality when the unit is woken from sleep mode.

When first turned on, the QX-8 automatically enters System-sleep mode, indicated by a green status LED. To activate the unit, simply press the left-hand button on the front of the unit, or the power button on the remote. If either button is held for three seconds, AyreLink connected devices will also be turned on.

Active Mode

Once in Active mode, the audio circuitry in the unit is unmuted. The currently selected input is displayed on the screen and any signal present at that input will be driven to the enabled output(s). When available, information or meta-data from a digital recording being played will be shown on the QX-8's display.

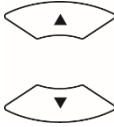

To make input selection easier, try disabling any inputs you aren't using through the menu.

When muted, no signal will be sent to the outputs.



When the headphones are disconnected, the QX-8 will automatically resume playback through the rear-panel outputs.



Volume Control

The volume control in the QX-8 may be controlled using the control ring on the front of the unit, the remote control handset, or a network application.

Input Selection

By pressing the left/right arrow keys on the control ring or right-hand button on the front panel, the currently selected input will cycle to the next enabled input. This may also be adjusted using the left/right arrow keys or number keys on the remote handset. To learn more about enabling/disabling inputs, see page 21.

Mute / System-sleep

A quick press of the left-hand button will mute the audio outputs of the QX-8. While muted, an icon will appear on the display. A second short press of the left-hand button will un-mute the unit.

By pressing and holding the left-hand button for three seconds, the QX-8 and any AyreLink connected devices will return to System-sleep mode.

Headphones

When either single-ended ($\frac{1}{4}$ ") or balanced headphones (3.5mm) are connected, the digital hub automatically reconfigures for headphone playback, and the headphone symbol is shown on the display.

By pressing the headphone button on the remote control, you can switch between headphone and rear-panel outputs while headphones are connected.

The display in the QX-8 is rated for years of use, but to keep it in best condition we recommend that the display be allowed to timeout.



Brightness button

Display

After a period of inactivity the display automatically powers off, indicated by a blue status LED. This minimizes the amount of active digital circuitry to ensure the best sound quality while also extending the lifetime of the display. This feature may be extended, shortened, or disabled entirely through the menu, see page 23.

The brightness of the display may be controlled via remote control. Each press of the brightness button cycles through the four available brightness settings.



Changing the brightness on your QX-8 will adjust the display brightness of any AyreLink connected components to the same level.

Sample Rate

When digital audio is playing, the QX-8 will display the sample rate it is receiving. If you are expecting a different sample rate than what the QX-8 shows, check the settings in your source software.

Meta-data

If “Track” or “Artist” information becomes available while using the Network input, it will be displayed on the screen.

*Not all HDCD tracks are
created the same.*

HDCD Indicators

If Pacific Microsonics HDCD headers are detected in the digital data-stream, the letters HDCD will appear on the screen to indicate the QX-8 is playing true HDCD. If HDCD appears in quotation marks, the header is not accompanied by any decodable information.

Pre-emphasis Indicator

The letters PRE beside the sample rate indicates that the current track was recorded with pre-emphasis, and the proper de-emphasis EQ is being applied.

Remote Handset

The provided remote control handset will operate the Ayre QX-8 as well as other Ayre 8 series products.

The top row of buttons contains illuminating product selection keys. Pressing the “dig” button will allow the remote to control the QX-8. Whenever another button is pressed, the key corresponding to the current selection will illuminate.

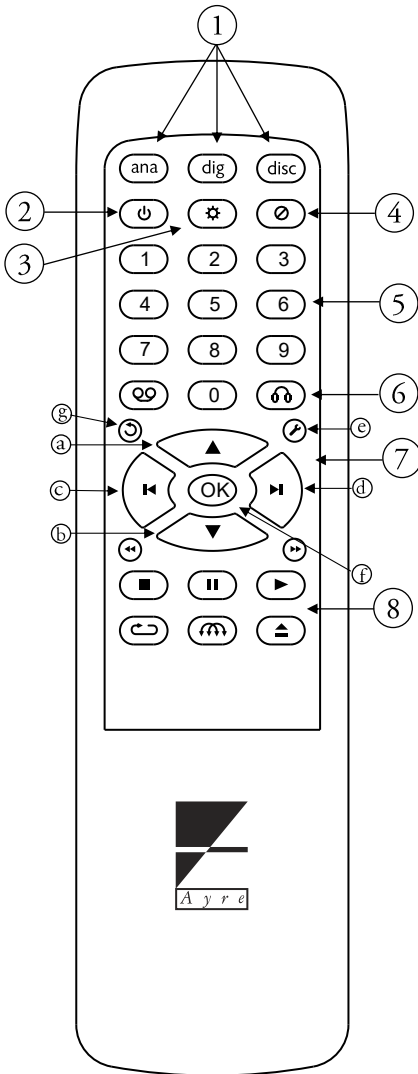

- 1) Product Selection Keys
- 2) System-sleep / Active Mode
- 3) Brightness Cycle
- 4) Mute Toggle
- 5) Number Keys (Input Selection)
- 6) Headphone button
- 7) Navigation keys
 - a. Up (Volume)
 - b. Down (Volume)
 - c. Left (Previous Input)
 - d. Right (Next Input)
 - e. Enter Setup
 - f. OK (Select)
 - g. Return
- 8) This section is for 8 series disc players

Customization

Your QX-8 offers a high level of flexibility in terms of setup. The following information will allow you to configure the unit in the best way for your system.

Setup Menu

To access and operate the menu, you may either use the included remote control or the two buttons to the left of the display.

Operation using the remote

To access the menu, press the Setup button on the remote. “Setup Menu” will be displayed on the screen briefly, then the main menu will load. All outputs are muted while the unit is in the setup menu.

Once in the menu, the navigation keys (up, down, left and right) allow you to adjust your selection in the menu. With the desired selection highlighted, press OK to select it. To return to the previous screen, press the Return button. To immediately exit the menu, you may press the Setup button at any time.



Setup button



Return button

Operation using front panel buttons

To access the menu, you must first place the unit into System-sleep mode. This can be done by pressing and holding the left-hand button for 3 seconds and will be indicated by a green status LED. Next, press and hold the right-hand button for three seconds. “Setup Menu” will be displayed on the screen briefly, then the root menu will load.

The control ring can be also used to adjust your current selection (up, down, left, right)

Once in the menu, the right-hand button will allow you to adjust your current selection; each press will cycle through the list of available options. With the desired selection highlighted, a quick press of the left-hand button will select it. To return to the previous screen, press and hold the left-hand button.

Screen layout and icons

The menu screen is organized with the section title at the top and a list of options below.

Arrow symbols indicate more content is available off-screen:



At any one time, four options may be displayed on the screen. An arrow symbol on either the left or right side of the screen indicates that more options are available off-screen, in that direction.

Setting Selection marker:



Some screens contain a list of sub-menus, while others control a specific setting. On a setting screen, the current setting is indicated by a mark to the left of that setting. Once a new setting has been selected, the mark moves to reflect the change.

Menu Structure and Contents

From the main menu, you will have access to the five main sub-menus: Input, Output, Display, Network, and System.

The setup menu has five sub-menus, which allows you to optimize the QX-8 for your system.

The **Input** sub-menu will allow you to access settings specific to each input installed in your QX-8.

The **Output** sub-menu lets you configure your QX-8 as a fixed volume DAC or a digital pre-amp.

The **Display** sub-menu will allow you to adjust the display timeout setting, which causes the display to turn off after a preset period of inactivity.

The **Network** sub-menu will allow you to access Wi-Fi setup functions, network connection information, network firmware updates, and network module reset.

The **System** sub-menu will allow you to set Auto-sleep mode, check current firmware revisions, show installed modules, and perform a factory reset.

Input Sub-menu

Settings will vary for the different input types.

After entering the Input sub-menu, select the input you would like to modify. The settings available for the selected input will appear.

Settings available for all inputs

Enable (On/Off) – This setting determines whether an input is enabled for use. Disabled inputs are not selectable, allowing quicker access to inputs that are in use. By default, all inputs are enabled.

Name – The name displayed for each input can be assigned individually with either a preset or a custom name. By selecting “Custom” from the name selection screen, you may modify the stored custom name for the selected input up to the character limit of ten. The default name for each input matches the input name on the rear-panel of the QX-8.

AyreLink ID (A – Z) – The AyreLink ID associated with an input refers to the source connected to that input. Selecting the correct ID allows for AyreLink functionality between your QX-8 and a connected Ayre source component. For example, if a CX-8 is connected via TOSLINK to the Optical 1 input of the QX-8, an AyreLink ID of “C” should be assigned to the Optical 1 input.

Word Clock Output (On / Off) – Some digital products have word clock inputs and provide higher performance when supplied with a high-quality external word clock. This setting determines whether this clock signal is active for the selected input.

Reset (Yes / No) – Selecting “Yes” will restore all settings for the selected input to their factory defaults.

The AyreLink ID setting allows the QX-8 to automatically configure when an Ayre source is turned on.

Note that Video Mode and Word Clock Output only affect the selected input.

USB and Ethernet sources maintain audio to video sync even while operating asynchronously.

Settings available for S/PDIF inputs only

Video Mode (Music / Video) – During normal operation (Music Mode), data from the AES/EBU, S/PDIF, and Optical inputs are buffered and re-clocked using Ayre’s patent-pending Asynchronous S/PDIF technology. Selecting Video Mode forces the QX-8 to synchronize with the incoming data stream, which will keep the audio and video in sync.



Music Mode provides optimal sound quality and should be used when the source does not include video.

Output Sub-menu

The output sub-menu allows you to configure the QX-8 for use as a digital preamplifier or as a DAC.

Output Mode (Preamp, DAC) – By selecting “Preamp”, the built-in digital volume control is enabled, allowing the QX-8 to drive a power amp directly. “DAC” mode should be used when a separate preamplifier is used to control the volume.

DAC Output Level (0dB, -6dB, -12dB) – After selecting the DAC output mode, you may adjust the fixed output level of the DAC in increments of 6dB. By default, the output level in DAC mode is full scale (0dB), but it can be lowered by -6dB or -12dB to accommodate higher efficiency systems.

Display Sub-menu

The Display sub-menu contains the Display Timeout setting.

Display Timeout (5s, 15s, 30s, 60s, Never) – While the system is active, the display will automatically turn off after a period of inactivity defined by this setting.



Please note that leaving the display timeout in “Never” mode can cause faster than normal fading of the display and negatively affects the sound quality.

Network Sub-menu

The Network sub-menu allows you to perform Wi-Fi setup procedures, access your device’s IP addresses, check for network firmware updates, and perform a network reset that clears your network settings.

Wi-Fi Setup – The AP and WPS functions found here allow you to connect your QX-8 to a home network. For detailed instructions, please refer to the Wi-Fi setup section of the manual (page 29).

Connection – The connection screen will display the QX-8’s current LAN and WLAN IP addresses.

Check for Update – Once confirmed, the QX-8 will attempt to contact Ayre’s FTP server and determine if the local firmware is the latest available. If an update is available, it will be installed automatically. For more information, refer to the Firmware Update section of the manual (page 25).

Reset – Once confirmed, any stored Wi-Fi network information, Device Names, and other network settings will be cleared to the defaults and the network module will reboot.

System Sub-menu

The System sub-menu provides access to system information as well as the Factory Reset function.

FW Revisions – The firmware revision screen contains all the current revision codes installed in the unit.

Options Installed – The QX-8 offers several optional inputs. This screen shows which of these options have been detected and are ready for use.

Factory Reset – The factory reset function restores all settings to their defaults.



Performing a factory reset will reset all names and settings for ALL inputs and outputs.

Firmware Updates

Firmware updates over the network may take up to 30 minutes, depending on your network connection.

Firmware updates will be made available for the QX-8 as new features are added or as ease of use is improved. There are two methods to update the firmware of the QX-8 – via Network or via USB flash drive.

For detailed information about firmware updates and to check for available updates, please visit <https://www.ayre.com/support/>



Do not turn off the QX-8 while updates are in progress.

Firmware Updates via Network

If the Network option is installed in your QX-8, all firmware updates (SYS, DSP, and NET) can be performed automatically over the Internet.

Whenever the unit enters System-sleep mode, it will attempt to contact Ayre's servers and check for available updates. If any are found, you will be prompted to download and install them. You may also manually check for updates using the menu.

Firmware Updates via USB

NET firmware can only be updated via the Network connection.

The system (SYS) and signal processing (DSP) firmware can be updated using the USB Firmware Update port on the rear of the unit.

If an error occurred during a network update that has affected your unit, try using the USB Firmware Update method to recover.

To successfully update over USB, ensure the file placement is correct. Also note file and folder names are case sensitive.

When the unit is first powered on with the On / Off rocker switch, it will automatically check for a USB flash drive in the USB Firmware Update port. If a drive is detected, it will search for available firmware files and install them.

To perform a USB firmware update, please refer to the following procedure.

- 1) If the QX-8's firmware revisions do not match the revisions available at <https://www.ayre.com/support/>, you may download the new files from the website to your computer by following the links on the page.
- 2) The new firmware will be in a compressed folder called "QX8boot.zip". This compressed folder contains two program files, "qx8_p---.hex" and "qx8_x---.bin". Place these two files into a folder called "QX8boot" in the root directory of a USB flash drive. Please note the folder and program files are case sensitive.



Both program files should be placed into the USB flash drive at the following directory location: "[Drive:]/QX8boot/"

- 3) Turn the power switch on the back panel of the QX-8 to the OFF position and allow several seconds for the device to power down.
- 4) Insert the USB flash drive into the port labeled "Firmware Update" on the back panel.



Be sure to insert the flash drive into the Firmware Update port and not either of the USB Host ports, as these will not allow the unit to update.

- 5) Turn the power switch on the back panel of the unit into the ON position. The firmware update will commence automatically, and the screen will show “Installing Update”.
- 6) Once the update is complete, the unit will start as normal. Once in the System-sleep state, return the unit to operation mode by pressing the left-hand button.
- 7) The USB flash drive can be safely removed from the Firmware Update port.

Networking

To begin streaming audio to your QX-8 over the network, you will first need to set up your connection. The QX-8 can be connected either with a standard Ethernet cable or with the included USB Wi-Fi adapter.

Network Connection

Once set up, the QX-8 will be available for playback from a variety of applications.

Connection integrity has a significant effect on sound quality. The best quality audio will be achieved with a short, hard-wired connection to your home network. If a wireless connection is required, the best performance will be achieved by keeping the distance between your QX-8 and wireless router to a minimum.

Connecting with an Ethernet cable

If available, a hard-wired Ethernet connection is the best way to connect your QX-8 to your home network.

Once connected to your home router with a standard Ethernet cable, the QX-8 will automatically connect to your home network and be available for use by any devices connected to the same network.

Connecting Wirelessly

The three methods below will allow you to connect to your home network via Wi-Fi using the included USB Wi-Fi adapter. After performing one of these procedures, your QX-8 will automatically connect to your home Wi-Fi when it is powered on.

Wi-Fi Connection using WPS

Wi-Fi Protected Setup (WPS) is a common feature in wireless routers.

If your Wi-Fi router supports WPS, this is likely the quickest and easiest way to connect your QX-8 to your home Wi-Fi network. You will need to know how to activate the WPS function on your wireless router.

- 1) Connect the included USB wireless network adapter to one of the two “USB Host” ports on the rear-panel of the QX-8.
- 2) Enter the Setup Menu and navigate to the Network sub-menu. From here, you can select “Wi-Fi Setup” and then “WPS Function”.
- 3) Once confirmed, wait for the QX-8 display to change from “WPS Function: Initializing” to “WPS Function: Running”.
- 4) Press the WPS button on your Wi-Fi router to begin the connection process.
- 5) The two devices will attempt to establish a connection, and when complete, the QX-8 will display “Connection success!” This may take about a minute.

With a temporary wired connection, your Wi-Fi network information can be provided to the QX-8.

To download mConnect, please visit the app store supported by your mobile device and search for “mConnect control”.

Wire-aided Wi-Fi Connection

To achieve the wire-aided Wi-Fi connection, you will need a smart device connected to your home network. You will also need to download and install the mConnect application to the device (page 33).

- 1) Connect the included USB Wi-Fi adapter to one of the two “USB Host” ports on the rear-panel of the QX-8. Also connect the unit to your home router using an Ethernet cable.
- 2) Using your smart device, open the mConnect application.
- 3) Access the mConnect setup menu using the gear icon on the player screen, then select “Device Setup”.
- 4) Select “Ayre QX-8” from the list of available devices. You may need to refresh the list.
- 5) Select “Wi-Fi Network Selection”.
- 6) Choose the desired Wi-Fi network from the list of available networks. You may need to refresh the list.
- 7) Type in your password. A notice will appear indicating “The device is attempting to connect to the network”. Press OK.
- 8) After the wireless connection is established, you may disconnect the Ethernet cable and relocate the QX-8 if necessary.

Wi-Fi Connection with the AP function

By hosting its own network temporarily, the QX-8 allows you to connect to it with a smart device and provide your Wi-Fi network information.

To download mConnect, please visit the app store supported by your mobile device and search for “mConnect control”.

The Access Point (AP) function causes the QX-8 to temporarily host its own Wi-Fi network. By connecting to this network with a smart device, you may provide the QX-8 with your own Wi-Fi network information, similar to wire-aided Wi-Fi connection.

To perform the Access Point procedure, you will need a smart device connected to your home network. You will also need to download and install the mConnect application to the device (page 33).

- 1) Connect the included USB Wi-Fi adapter to one of the two “USB Host” ports on the rear-panel of the QX-8.
- 2) Enter the Setup Menu and navigate to the Network sub-menu. From here you can select “Wi-Fi Setup” and then the “AP Function”.
- 3) Once “AP Function” has been selected, and confirmed, wait for the QX-8 display to change from “AP Function: Initializing” to “AP Function: Running”.
- 4) Using your smart device, you will need to connect to the Wi-Fi network hosted by your QX-8, named “QX-8_---”. The password is “password”.
- 5) Once connected to the “QX-8_---” Wi-Fi network, open the mConnect application.



- 6) In the mConnect app, access the setup menu using the gear icon on the “Player” tab, then select “Device Setup”.
- 7) Select “Ayre QX-8” from the list of available devices. You may need to refresh the list.
- 8) Select “Wi-Fi Network Selection”.
- 9) Choose the desired Wi-Fi network from the list of available networks. You may need to refresh the list.
- 10) Type in your Wi-Fi network password then select “Join this Network”. A notice will appear indicating, “The device is attempting to connect to the network”. Press “OK”.
- 11) At this point, the QX-8 will stop hosting its own network and attempt to join the network you selected. If it is successful, the QX-8 will display “Connection success!”

Network Applications

The QX-8 network module supports a variety of network standards, which allows you to stream to and control the device. Below are a few of the supported applications. For a complete list, please visit:

<https://streaming.ayre.com>

To download mConnect, please visit the app store supported by your mobile device and search for “mConnect control”.

There are a number of compatible network applications available. Here are a few you might like.

mConnect Control

Some features supported by the QX-8 may only be available through the “mConnect Control” application. For a complete list of features, please visit the website above.

Spotify

With a Spotify Premium account, the QX-8 becomes an available Spotify Connect device. Using the Spotify application, select the “Ayre QX-8” as the playback device.

Roon

Roon is an advanced and powerful software application capable of relating, organizing and playing back a large digitally stored music library. As shipped from the factory, the QX-8 is a “Roon Ready Endpoint”, which will allow you to connect to and control the QX-8 from a Roon control application.

Generic UPnP Applications

A variety of applications across platforms support the DLNA standard, which allows them to stream music files to the QX-8. Searching for “UPnP control apps” in your device’s application store will help you find available options.

Specifications

<i>Digital Inputs</i>	Optical/SPDIF/AES <ul style="list-style-type: none">• PCM 16, 20, 24 bits at 44.1 - 192 kHz• DSD64 (as DoP) USB <ul style="list-style-type: none">• PCM 16, 20, 24 bits at 44.1 - 384 kHz• DSD64 and DSD128 (as DoP) Network <ul style="list-style-type: none">• PCM 16, 20, 24 bits at 44.1 - 192 kHz• DSD64
<i>XLR Input Polarity</i>	Pin 1 = Ground Pin 2 = Non-inverting (Positive) Pin 3 = Inverting (Negative)
<i>Headphone Outputs</i>	9 V rms max balanced / 4.5 V rms max single-ended
<i>Power Consumption</i>	60 watts in operating mode, no signal
<i>IEC Power Fuse Values</i>	100/120V: 1.0A slow blow 220/230/240V: 0.5A slow blow
<i>Dimensions</i>	17.25" W x 13.00" D x 3.75" H (44 cm x 33 cm x 10 cm)
<i>Weight</i>	12.5 pounds (5.7 kgs)

In case of

Trouble

In the event that you experience any technical difficulties with your Ayre product, the following items may help to solve the problem or track down the cause.

Fault Messages

The Ayre QX-8 will display faults when a problem occurs. The following faults are listed, along with possible solutions to the problem:

Low Voltage

If you have trouble clearing any of these faults, contact your local Ayre dealer.

If the AC line voltage supplied to the unit drops below operable levels, this fault will be displayed. Once normal power is restored to the unit, the fault should clear itself.

If the fault persists, try restarting the QX-8.

Update Error

If an error is detected during a firmware update process, this fault will be displayed.

Please try to update the unit again using the USB Firmware update method (page 25).

If the unit has become unresponsive, or if network functionality has been impacted, the update error may have critically impacted the system and must be taken to an authorized Ayre dealer for repair.

Persistent Faults

In the event that any fault persists, or if another issue occurs but is not displayed, please contact your Ayre dealer for further assistance.

Network Connection Issues

If the QX-8 cannot be seen by devices on your home network or if playback is inconsistent, the following steps may help:

If you are using a wireless connection, try connecting the QX-8 with an Ethernet cable to see if that resolves the problem.

Visit the “Network Info” page in the setup menu (page 23) and verify that the QX-8 has been assigned an IP address on your home network. If both the “LAN IP” and “WLAN IP” fields are blank, or zeroes, there may be a connection issue between the QX-8 and your home network. Try reviewing the connection steps (page 28).

If you are experiencing streaming issues, visit the “FW Revisions” page in the setup menu (page 24) and verify that your NET firmware version matches the most recent found on the support web page.

USB Connection Issues

If you are experiencing any issues with the USB audio input, please try the following:

Try using the stock USB A to B cable that came with your QX-8. Some custom USB cables, or cables of excessive length, can cause issues with USB connectivity and playback.

If the QX-8 appears as “Unknown USB device”, or something similar on your computer, you may be experiencing a driver related issue. For more information about drivers, visit the product support page at <https://www.ayre.com/support/>.

Warranty

North American Warranty

Your Ayre Acoustics QX-8 Digital Hub is warranted against defects in materials and workmanship for a period of five years from the date the unit was shipped from Ayre. Additionally, you have the option at no cost to begin the warranty from your date of purchase by returning the completed Warranty Registration Card and a photocopy of your original purchase receipt in the enclosed postage-paid envelope to Ayre within ninety days of product delivery.

During the warranty period, Ayre will repair, or at our discretion, replace a product found to be faulty. All warranty repairs or service must be conducted by an authorized Ayre agent. Please contact your Ayre dealer for any service requests.

For further information regarding Ayre's warranty policy, please refer to the Warranty Registration Card included with your product.

North American Warranty Statement

1. If any defects are found in the materials or workmanship of this Ayre product within the warranty period, the unit will be repaired or replaced by Ayre Acoustics, Inc. (Ayre) or its authorized agent.

2. Purchaser must return the product, packed in the original shipping carton, freight prepaid to:

Ayre Acoustics, Inc.
6268 Monarch Park Place
Niwot, Colorado 80503

or to Ayre's authorized agent. The product must be accompanied by a written description of the defect and a photocopy of your original purchase receipt.

Ayre will not be responsible for any shipping damage and strongly recommends the purchase of shipping insurance.

3. Ayre reserves the right to inspect any product that is the subject of any warranty claim prior to repairing or replacing it. Final determination of warranty coverage lies solely with Ayre. Out-of-warranty claims will be billed for labor, materials, return freight, and insurance as required.

Any product for which a warranty claim is accepted will be returned to the purchaser and the cost of return shipping and insurance will be factory prepaid within the boundaries of the USA. Units to be shipped outside of the USA will be shipped freight collect only.

4. Ayre strives to manufacture the finest possible equipment, and therefore reserves the right to make improvements on its products, without necessarily assuming any obligation to retrofit such changes upon its previously manufactured models.

5. The above warranty is the sole warranty given by Ayre and is in lieu of all other warranties. All implied warranties, including warranties of merchantability or fitness for any particular purpose shall be strictly limited to the duration of the above warranty. Ayre shall have no further obligation of any kind, whether express or implied. Further, Ayre shall in no event be obligated for any incidental or consequential damages as a result of any defect or any warranty claim, whether express or implied.

6. Ayre does not authorize any third party, including any dealer or sales representative, to assume any liability of Ayre or make any warranty for Ayre. The unit must not have been altered or improperly serviced. The serial number on the unit must not have been altered or removed.

7. The remaining period of this warranty is only transferable to subsequent purchasers if the product is resold by an authorized Ayre dealer.

International Warranty

Warranty terms outside of North America may vary. Please contact the authorized Ayre distributor in your country of purchase for the terms of warranty and also the service itself.

A Place for

Notes

Serial Number: _____

Purchase Date: _____

Dealer: _____

Salesperson: _____

*Ayre Acoustics, Inc.
6268 Monarch Park Place
Niwot, Colorado 80503*

*www.ayre.com
+1-303-442-7300*